



FEATURES & BENEFITS

- Tested in accordance to BBA
- Six suited finishes
- High profile to give greater knuckle clearance during operation
- Non-handed for ease of stocking
- Push-to-open locking mechanism
- Available in locking or non-locking variants
- Green button available for fire egress applications
- Colour co-ordinated screw covers
- Profile-specific spindle lengths
- Packaged as 10 per box, 6 boxes per carton

INLINE WINDOW HANDLE HB 117

The inline window handle is engineered to work with all standard espagnolette and shoot bolt mechanisms with 43mm centres. Suitable for PVC-u, Aluminium and Timber window profiles, this range offers outstanding performance and reliability. Aimed at the prestigious end of the market, the Claymore inline window handle is produced to meet the demands associated with the new build and commercial sectors, while still retaining the aesthetical and contemporary design that appeals to the domestic and trade fabricator.

CLAYMORE

Fitted to Last

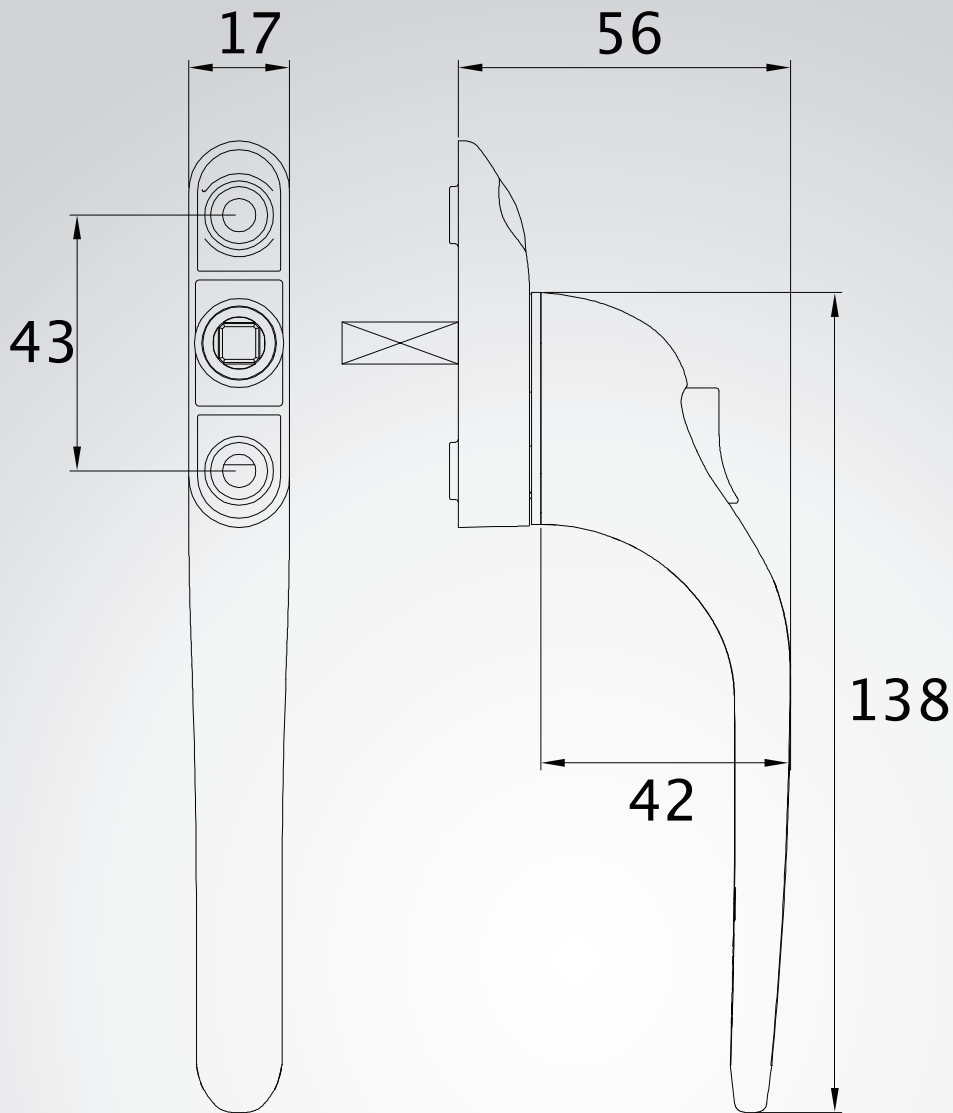

BBA Assessment Report No.S2/49995

Colour	Coating Type	BS EN 1670 : 2007
White	Powder Coat	Grade 5 (480 hours)
Black	Powder Coat	Grade 5 (480 hours)
Polished Gold	Electrophoretic Lacquer	Grade 4 (240 hours)
Polished Chrome	Electro-Plating	Grade 4 (240 hours)
Smoked Chrome	Electro-Plating	Grade 4 (240 hours)
Satin Silver	Electro-Plating	Grade 4 (240 hours)

AVAILABLE COLOURS

- White
- Black
- Polished Gold
- Polished Chrome
- Smoked Chrome
- Satin Silver

Product Code	Product Type	Available Spindles
HB 117PK	Locking	10, 15, 20, 25, 30, 35, 43, 45, 50
HB 117P	Non-locking	
HB 117PE	Egress	